

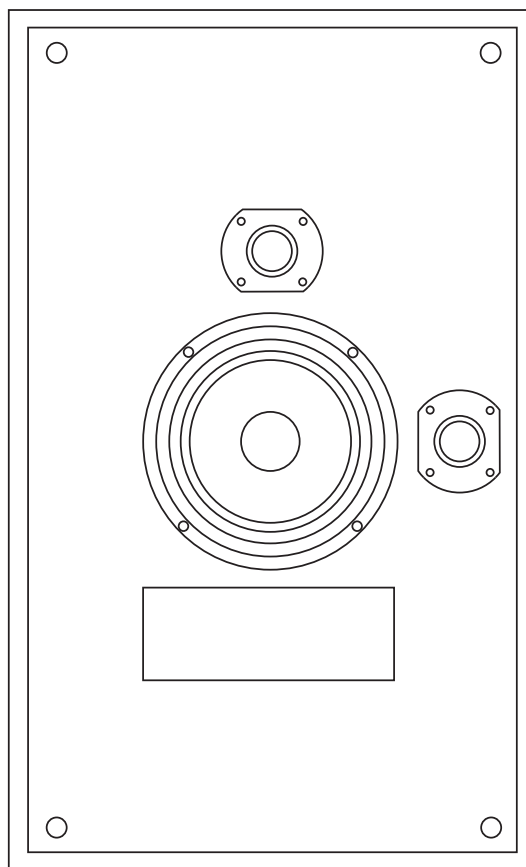

wafer[™]

Loudspeaker
user-guide



Serial No

Builder

wafer1[™]

wafer2[™]

Contents

- 5 General usage guidelines
- 8 Introduction
- 9 The approach
- 10 Unpacking
- 11 Our attention to detail
- 12 **wafer™** series installation examples
- 13 Connections
- 14 **wafer™** control
- 15 control -
- 16 Using
- 17 and **H-Line ATL™**
- 18 Wall mounting the
- 20 Running or breaking in
- 21 Suggested associate loudspeakers
- 24 Service
- 25 Warranty on-line
- 26 Warranty certificate - Part 1
- 27 Warranty certificate - Part 2
- 28 Help us improve - your comments
- 29 Specifications
- 30 Inspection certificate

Product Support

For product support, accessories or servicing advice, please contact a PMC authorised dealer see www.pmc-speakers.com.

Warranty Certificate

Please take a few moments to complete the warranty card at the back of this booklet or register at www.pmc-speakers.com. This records the purchase of your loudspeakers and provides you, the customer an opportunity to make suggestions and provide feedback directly to PMC.

Company Details

PMC LIMITED

43-45 CRAWLEY GREEN ROAD LUTON LU2 OAA UK

T 0870 4441044 F 0870 4441045

email sales@promonitor.co.uk web www.pmc-speakers.com

PMC USA LLC

17952 SKY PARK CIRCLE Building 45 SUITE A IRVINE CA 92614 USA

T 949 861 3350 F 949 861 3352

email sales@pmc-speakers.us web www.pmc-speakers.com

© 2009 PMC. All rights reserved.

Version 3 - 5662

This document should not be construed as a commitment on the part of PMC. The information it contains is subject to change without notice. PMC assumes no responsibility for errors that may appear within this document.

CE Conformity PMC passive loudspeakers conform to CE Directive LVD 73/23/EEC and EMC 89/336/EEC.

WEEE European directive - PMC Limited is a member of a National Compliance scheme and have gained the associated certification of compliance and the following registration number from the Environment Agency WEEE/GJ0101WU

WEEE EU Directive



This symbol on the product or in/on its packaging indicates that this product must not be disposed of with other household waste.

It is the responsibility of the owner to dispose of waste equipment via a designated collection point for the recycling of waste electrical and electronic equipment.

The recycling of your waste equipment is an attempt to conserve natural resources and ensures that it is recycled in a manner that protects human health and the environment. For more information about where you dispose of your waste equipment for recycling, please contact your local waste/recycling authority or the dealer from whom you purchased the product.

General usage guidelines

- 1 Read these instructions and keep them in a safe place for further reference.
- 2 Heed all electrical safety warnings, including any on the loudspeakers themselves.
- 3 Do not use the loudspeakers near water.
- 4 Clean only with a dry, lint-free, cloth.
- 5 Do not install near any heat sources such as radiators, ovens or other equipment that produce excessive heat.
- 6 High volume audio signals, however short their duration, have the potential to cause hearing damage. Use care when setting the system volume level to ensure playback sound pressure levels remain within comfortable limits.
- 7 Refer all servicing to qualified service personnel. Servicing is required when the apparatus has been damaged in any way or exhibits a distinct or sudden change of operation or performance.
- 8 The **wafer**™ series is not magnetically shielded, please ensure that they are positioned at least 1 metre/3 feet away from items that could be damaged by stray magnetic fields. Conventional glass tube (CRT) televisions and computer monitors together with media such as floppy discs, cassettes and videotapes are particularly susceptible.
- 9 PMC has made efforts to provide accurate installation information and good quality fixings, PMC Ltd / PMC USA LLC cannot be held responsible or liable for injuries or property damage - direct, indirect or consequential - arising out of use or inability to use this product safely and properly.

Congratulations you have joined the elite

*With PMC you can to hear exactly what the artist intended,
not a poor interpretation.*

Stevie Wonder Prince Google
Coldplay Kraftwerk Peter Gabriel
Robbie Williams Brian May
Eleanor McEvoy Francis Rossi -
Status Quo Brian Ferry
Peter Andre Bryston Tori Amos
Underworld Crystal Method
Tony Bennett John Rutter
Rough Trade BBC Radio BBC TV
Capital Radio Piccadilly
Radio RTL Emil Berliner/Deutsche
Grammophon NFL (National
Football League) teldex Studios
Hospital HDTV Broadcast Studios
Digidesign Siemens EMI Royal
Shakespeare Company DECCA
The Moving Picture Company
Paul Merton ORF The University of
Music - Düsseldorf The Royal
School of Music JVC DENON UK
The Royal Astronomical Society
Warner Music Capitol records
Chesky records N.Y. University



Robbie Williams

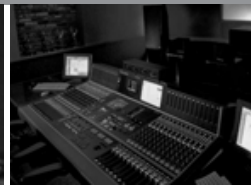

Advantage - USA



BBC London - UK



Francis Rossi



Mastermix - USA



Pierce Rooms - UK

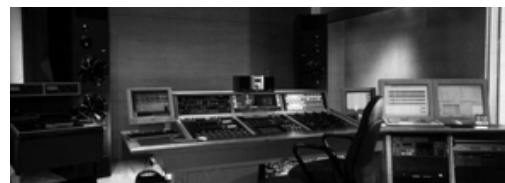

Nautilus Masterung - Italy



Metropolis - UK



Brian May



Orf - Austria

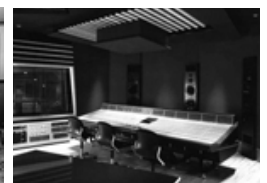

Metropolis - UK



Teldex - Berlin

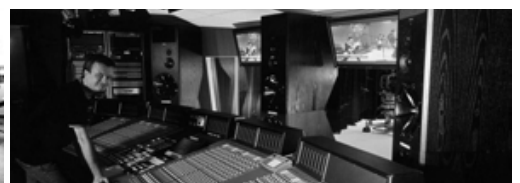

The Hospital Studio HDTV Centre - UK



Telegenic - UK

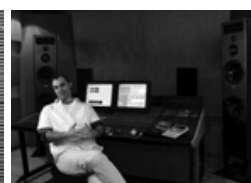

Swoon Factory - Austria



Optimum Mastering - UK



Teldex - Berlin



Emil Berliner Studios - Berlin



Studio Delphine - France



BBC Sounds One OB - UK

A message from Peter Thomas -
arguably the world's smartest
loudspeaker designer ...
and a truly obsessive audiophile.



Our sole aim while designing loudspeakers was to recreate the true essence of an artist's intention, combining an ultimate level in sonic resolution with solid engineering principles.

We believe that the same loudspeaker can be used throughout the entire audio chain - from composer to studio or film stage, and then finally the consumer. Our unswerving passion for getting it right has made this goal possible.

Thank you for choosing PMC products. It is now time for you to read the user guide, press the play button, and realise just how much you've been missing.

A large, stylized handwritten signature in grey ink that reads "Peter Thomas". The signature is written in a cursive, flowing style. To the right of the signature, there are several horizontal lines, suggesting a signature line on a document.

Peter Thomas

Owner & Chief Designer

Introduction

The **wafer**™ series of in & on-wall loudspeakers are a true breakthrough and encompass PMC's award-winning professional monitoring heritage in a slim and elegant design, ideally suited to match modern décor and lifestyles.

PMC products are to be found in every demanding environment, from broadcast and major film scoring to CD and DVD mastering. No other manufacturer can rival the accumulated technical knowledge and high level of engineering excellence PMC has developed over many years at the peak of professional monitoring. This expertise has been encapsulated in the development and production of the PMC consumer range.

The **wafer**™ series is ideal for stereo or all channels of a surround system. The **wafer**™ has been engineered with an identical tonal balance and similar dispersion characteristics to all PMC models, thereby any combination will afford seamless integration and a perfect audio picture. The professionally proven TLE1 active subwoofer can also partner any of the range to provide the ultimate in low frequency power and musicality.

See page 21 of this user guide & www.pmc-speakers.com



‘Closing the loop between the studio and the home’

PMC's **ATL**[™] Approach

The world's leading professionals rely on the accuracy of PMC's **ATL**[™] designs everyday to create much of the music and sound you hear everyday.

PMC's **ATL**[™] (Advanced Transmission Line) enclosures have taken loudspeaker design to the highest level. A PMC transmission line design utilises sophisticated cabinet construction, proprietary drive units and patented absorption materials and techniques. The benefits are enormous compared to the relatively simple sealed and ported models currently available elsewhere.

The main driver is placed at one end of a long tunnel (the transmission line), which is heavily damped with absorbent acoustic material. This material is specified to absorb the upper bass and higher frequencies that radiate from the rear of the main driver. The lowest frequencies, which remain in phase, then emerge from the large vent at the end of the line, which essentially acts as a second driver. One advantage to this approach is that the air pressure loading the main driver is maintained, thus controlling the driver over a wide frequency range, which in turn significantly reduces distortion. A spin-off from the lack of distortion is that the upper bass and midrange is not masked by harmonic distortion residing

in the very low frequencies. The result is PMC characteristic transparent midrange and fast, attacking bass notes, all with outstanding clarity. A further advantage of the transmission line approach is a cabinet that produces a higher SPL and

lower bass extension than a ported or sealed design of a similar size.

Moreover, as the loading on the main driver is maintained at all volumes, the frequency response also remains consistent regardless of listening level. Neither casual late night listening nor prolonged monitoring sessions have to be conducted at high volumes to achieve maximum bass response, a characteristic that is especially suited to the home user.

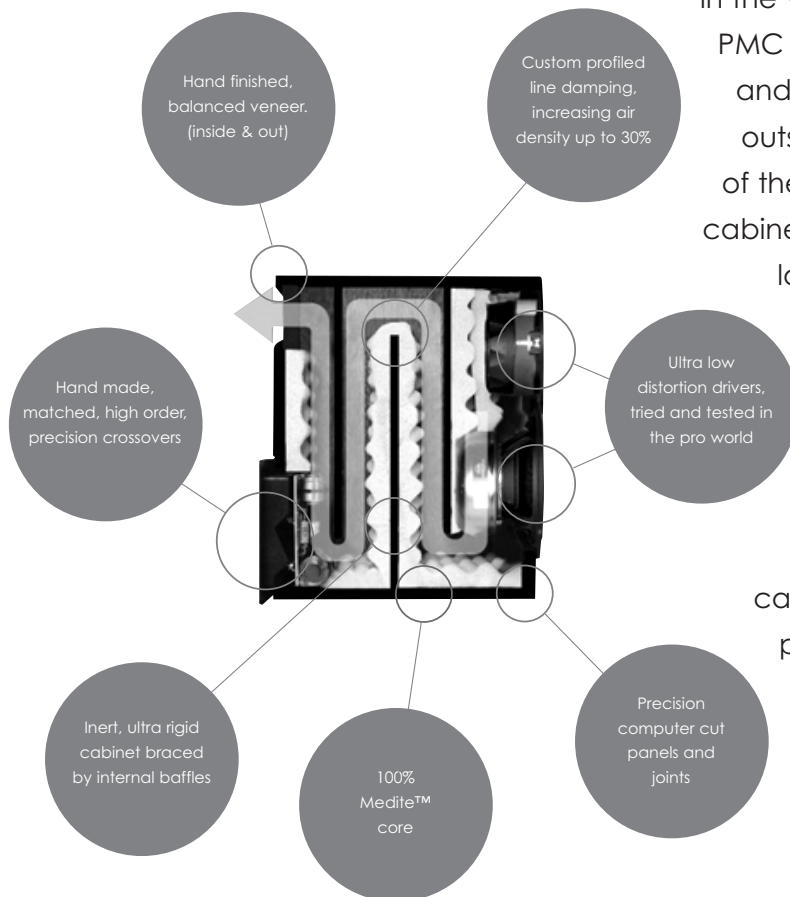

DB11 - The smallest **ATL**[™] in the range



Unpacking

Please retain your packaging for future use as all PMC cartons are durable, reusable and can be employed to safely transport your loudspeakers should they be relocated.

Much of the packing is constructed from recyclable materials, so if you are to dispose of it please do so in an environmentally friendly manner.



Packing materials can pose danger to animals, the young and vulnerable. Ensure these items are kept or disposed of safely.



Our attention to detail

All PMC loudspeakers are hand-built in the U.K. using individual components that are matched to our reference model; this includes the structural integrity of every cabinet and the testing and recording of each component. This guarantees it will be within our strict tolerances and ensures your purchase sounds identical to the original design. Each completed loudspeaker then undergoes a set of objective and subjective measurements - frequency response sweeps ensure that the design meets our exacting performance criteria, and then listening tests are conducted against the reference model using a wide variety of material, from a benchmark BBC speech test to classical music, pop and rock.



wafer™ series installation examples

Mixing and matching any of the **wafer™** series and PMC's consumer range creates a supreme and unbeatable surround system.

See page 21

wafer1™ series installation examples

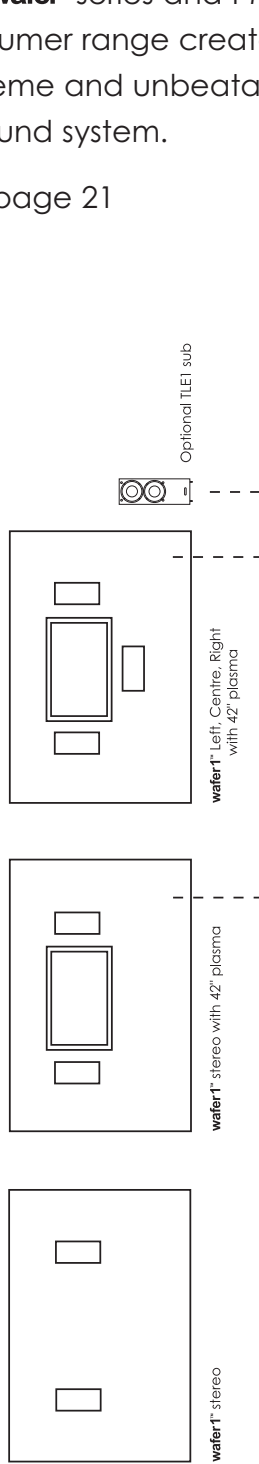

wafer2™ series installation examples

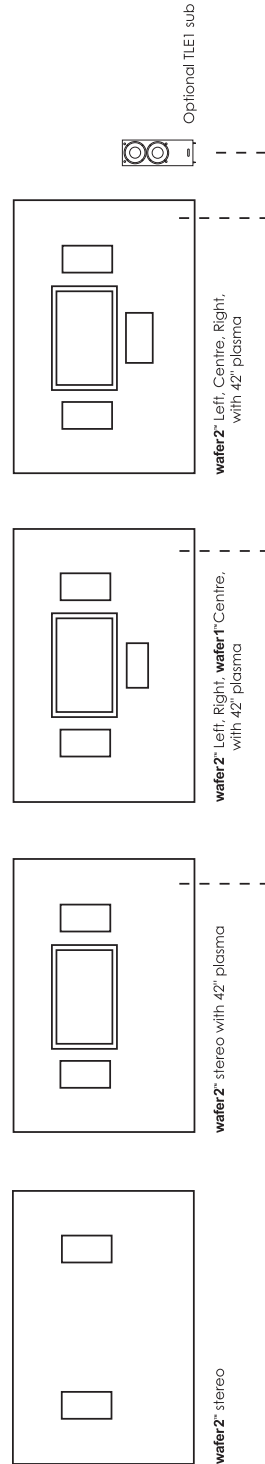

wafer™ series installation examples with projection screens

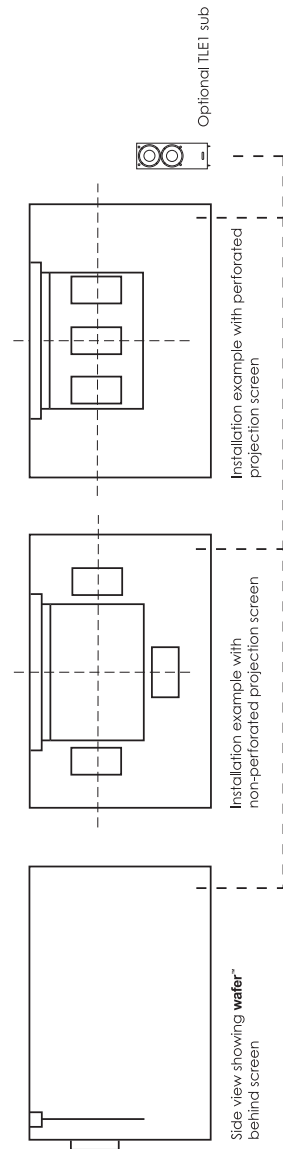

Connections

To avoid potential damage, please ensure that your power amplifier(s) or receiver is turned off before making or breaking any loudspeaker connections.

When selecting cables for use with your PMC loudspeakers, ensure that their construction is of a high enough quality to withstand the rigours of everyday use. While bare wire can be accommodated by the **wafer**[™] binding posts, we recommend the use of either spade lugs or 4mm banana plugs in order to maintain an electrical connection of the highest integrity and avoid the possibility of short circuits. Please consult your dealer for more information regarding cable lengths and termination options.

It is of vital importance to observe the polarity markings and maintain positive-to-positive and negative-to-negative connections from amplifier or receiver to the **wafer**[™]. The **wafer**[™] terminals are colour-coded to aid in their identification, positive terminals are red, negative terminals are black.

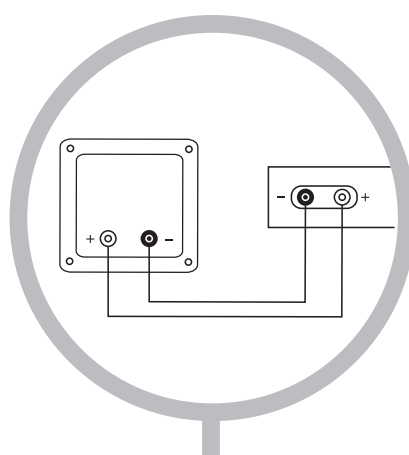

wafer[™] back panel

wafer™ control

- high frequency adjustment

Fine adjustment for perfect definition.

The **wafer™** sports a three position tweeter level control to ensure a perfect tonal integration into even the most difficult environment.

FLAT

The **FLAT** setting is perfect for the majority of installations.

HF-

Rooms with very little soft furnishings, like kitchens, can emphasise the high frequency, so a reduction may be desirable by moving the switch to the **HF-** position.

HF+

Conversely a very heavily furnished absorbent room or if the **wafer™** is placed behind a perforated projector screen may need a small high frequency boost to improve definition. Set to the **HF+** position.

These are not hard and fast rules, as every listening environment has its own distinct acoustic. For the best results listen to the same recording on each of the HF settings and adjusting accordingly.

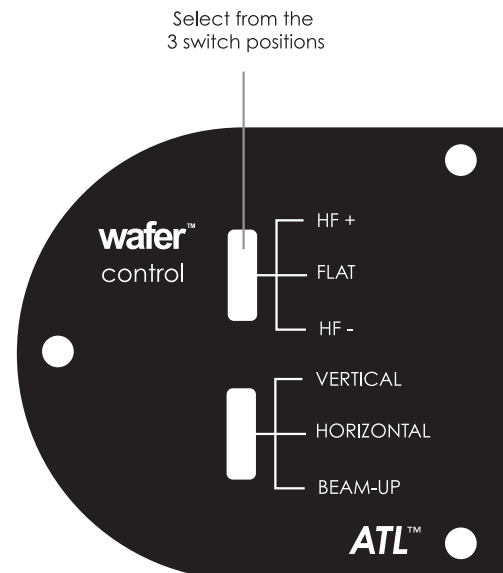

wafer™ control

- TT Technology™

Perfect response in either horizontal or vertical placement.

The **wafer™** has a number of innovative features that will further enhance the quality of sound so it can be sited where it is convenient and most pleasing to the eye.

The first of these is **TT-Technology™**. This feature has two distinct benefits; firstly, either tweeter can be switched to ensure a perfect response in either horizontal or vertical placement.

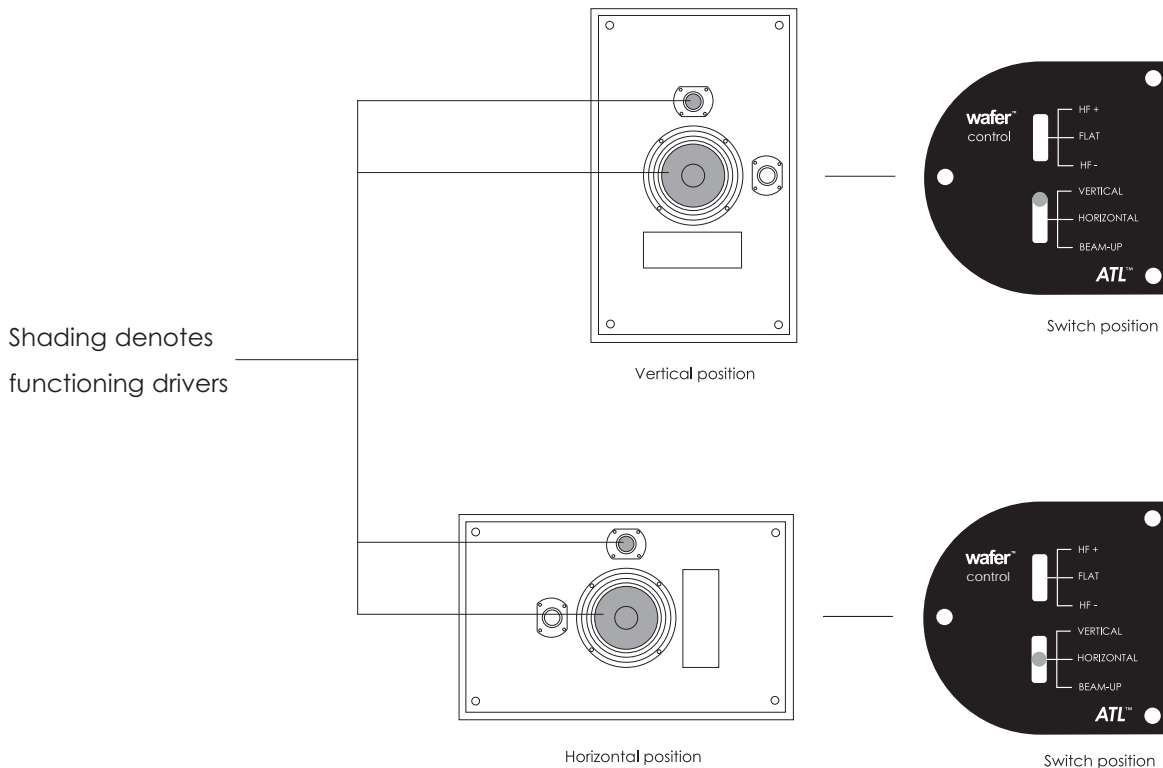

wafer™ control

- using TT Technology™

to ensure high performance when placement is less than ideal.

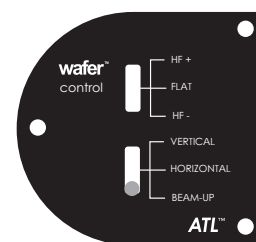
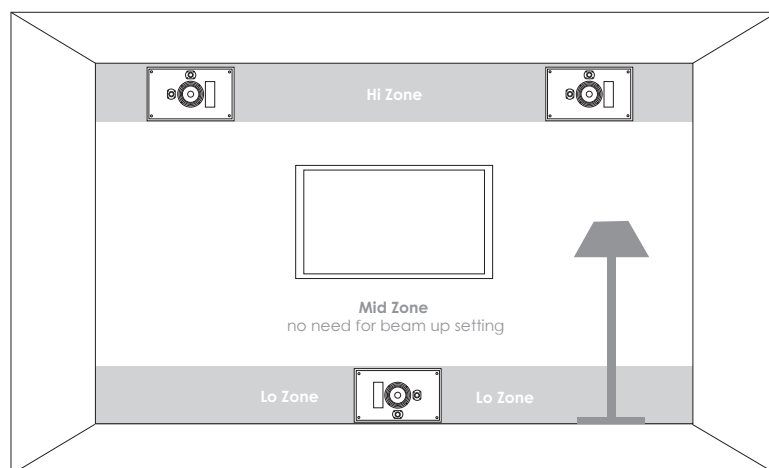

Switch in the 'Beam-Up' position

PMC's **TT-Technology™** also allows for steerable image techniques which utilises both tweeters to tilt the direction of the sound - a perfect solution if the **wafer™** is placed very much higher or lower than the listening position.

(This mode will only function when the cabinet is in the correct horizontal position with the **wafer™** controls set as per the diagram above)

Standard in-wall and on-wall designs are compromised by the large surface area of their front baffle that surrounds the drive units. This detrimental effect is best compared with cupping your hands around your mouth whilst speaking. PMC's acoustic specialists have developed a unique, structured, absorbent surface that prevents these unwanted characteristic sound waves being reflected. The drive units behave as though in free space and concentrate pure, untainted audio directly into the listening space.

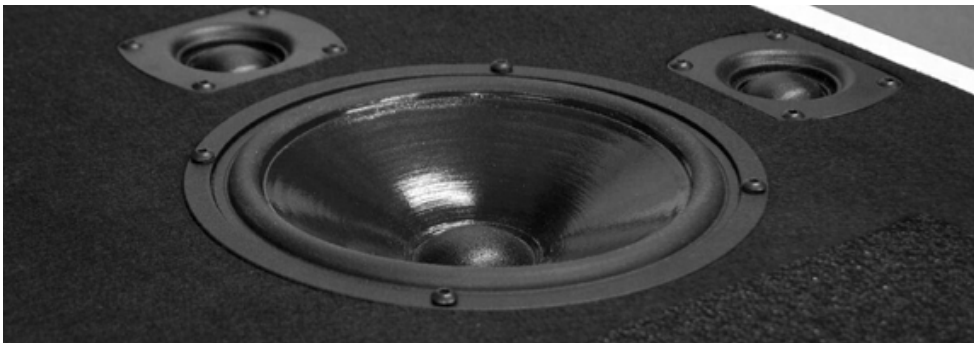
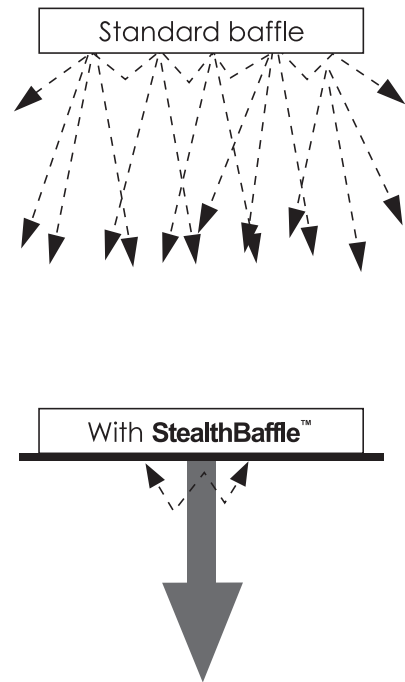

The ultra-shallow '**H-Line™**' interior of each cabinet is divided to create a long chamber, which is in turn lined with special acoustic materials. The result is an expansive, dynamic soundstage, with the type of deep bass one would only expect from a speaker many times the size.



wall mounting the wafer™

Warning

Carefully assess the make-up, strength and construction of the surface you are mounting to. Ensure you avoid concealed services e.g. pipes, cables etc. The fixings supplied are suitable for a solid wall, e.g. brick. Other surfaces with less substantial construction will require specialist fixings, (not supplied). If in doubt, please consult a qualified professional.

Before embarking on the installation ensure the kit is complete.

Check list

- 1 x Large printed card template printed on either side for horizontal or vertical placement.
- 2 x Adjustable speaker plates (20mm x 80mm)
- 2 x Wall mounting plates (85mm x 45mm)
- 3 x Long screws
- 3 x Short screws
- 3 x Wall plugs
- 2 x Soft, self adhesive feet



wall mounting the (cont...)

- 1** As the **wafer**™ can be mounted vertically or horizontally, firstly choose which orientation you require and select the corresponding side of the large printed card template included within the packing.
- 2** Position the template in the desired point on the wall ensuring it is level. The dotted lines denote the horizontal and vertical centres of the **wafer**™. This will ensure accuracy if you are attempting to place the cabinets centrally, adjacent or under a screen.
- 3** Mark the wall through the template using the six points denoted by crosses. These correspond identically to the holes in the wall mounting plates.
- 4** Drill the holes in the wall at least 45mm deep. Insert the six plastic wall plugs and screw the plates to the wall using the six long screws.
- 5** The cabinet can be mounted in vertical or horizontal positions. This will determine to which top edge the plates will be best attached. (See the Positioning section of the manual for details) There are small pilot holes positioned 30mm from the edges of the cabinet to locate the four short screws that attach the adjustable speaker plates to the cabinet.
- 6** Stick one of the soft adhesive feet in either bottom corners of the rear of the cabinets approximately 30mm in from the edges of the cabinet.
- 7** Connect the loudspeaker cable to the **wafer**™. RED + / BLACK – (See Connections section of the manual)
- 8** Locate the prongs of the wall plates with the speaker plates and slide the **wafer**™ down until it is securely fixed. If the **wafer**™ is not perfectly level remove the cabinet from the wall and adjust the levels of the speaker plates.

PMC has made efforts to provide accurate installation information and good quality fixings. PMC Ltd / PMC USA LLC cannot be held responsible or liable for injuries or property damage - direct, indirect or consequential - arising out of use or inability to use this product safely and properly.



running or breaking in

When loudspeakers are new they will take time to reach their full potential.

It is often debated whether any solid-state equipment, such as CD players or transistor-based power amplifiers change with use, but the characteristics of mechanical devices such as loudspeakers do alter and improve their performance significantly after a short 'running in' period.

The science is simple; as the soft material surrounding the dome or woofer cone is flexed it will eventually reach a point where it has optimum compliancy allowing the drive unit to move more freely. This translates to greater accuracy and speed of attack in the bass region and the mid and high frequency produces a far more vivid audio picture. This short 'running in' period takes approximately 15 hours of normal use.

15+ hours to run-in

suggested associate loudspeakers

PMC manufacture a large selection of loudspeakers and sub-woofers to meet a range of budgets and uses, from compact, audiophile designs to large studio monitors.

The following products make ideal companions to create an unbeatable surround system or for supreme audio throughout the home.

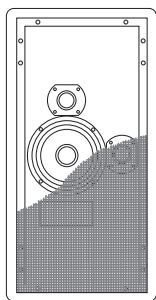

wafer1-iv™
(Two Way in-wall monitor)

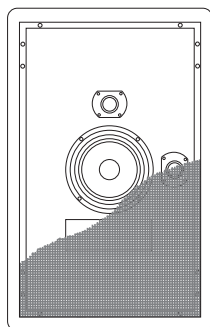

wafer 2-iv™
(Larger Two way in-wall monitor)

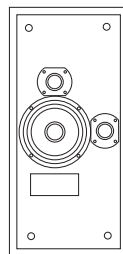

wafer 1™
(Two way on-wall monitor)

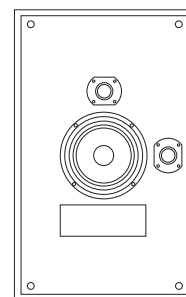

wafer 2™
(Larger, Two way on-wall monitor)

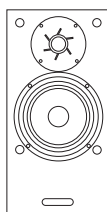

TB2i
(Larger, Two way monitor)

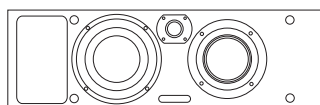

CB6i
(Three way magnetically screened horizontal centre)

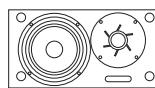

DB1M-Ci
(Magnetically screened horizontal centre channel)

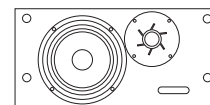

TB2M-Ci
(Larger, magnetically screened horizontal centre)

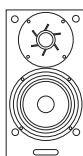

DB1i
(Compact two way monitor)

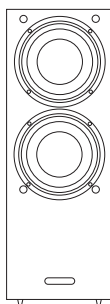

TLE1
(Active Subwoofer)



GB1i
(Compact, Two Way Floorstander)

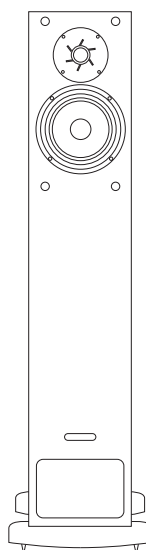

FB1i
(Two Way, Floorstander)

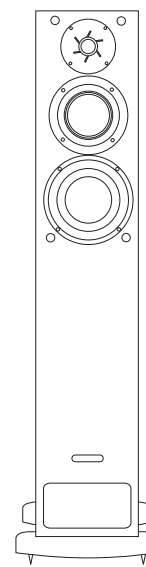

OB1i
(Larger, Three Way Floorstander)

suggested associate loudspeakers (cont...)

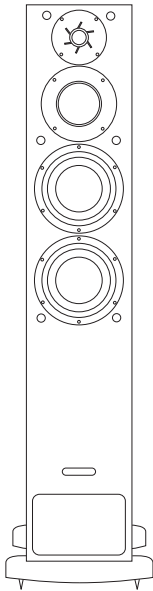

PB1i

(Larger Three way floorstander with twin bass drivers)

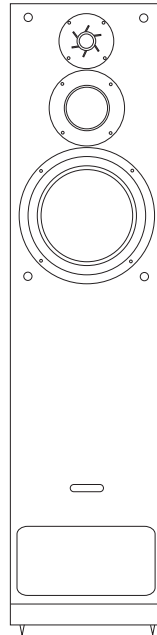

EB1i

(Large Three way floorstander with a PMC 10" Piston bass driver)

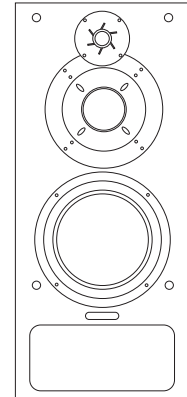

IB2i

(Three way stand mount with a PMC 75mm mid and a PMC 10" Piston bass driver)

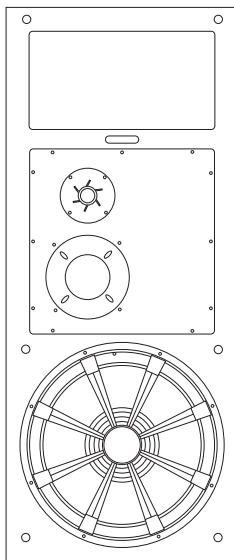

BB5i

(Three way stand mount with a PMC 75mm mid and a 15" Radial™ bass driver)

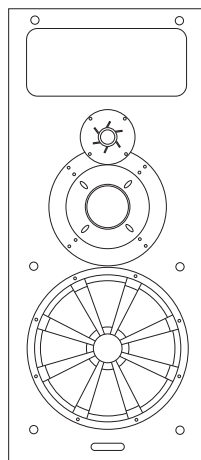

MB2i

(Three way stand mount with a PMC 75mm mid and a 12" Radial™ bass driver)

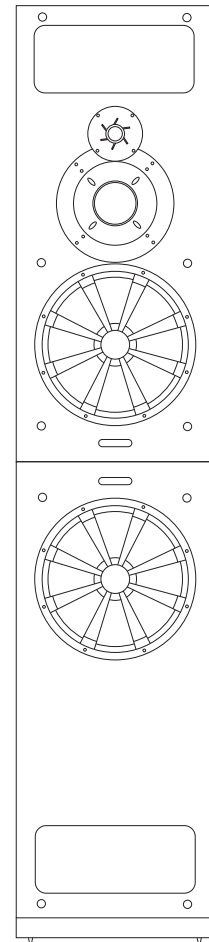

MB2 XBDi

(Large Three way floorstander with a PMC 75mm mid & twin 12" Radial™ bass drivers)

suggested associate loudspeakers (cont...)

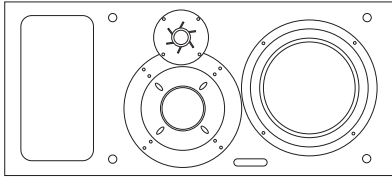

IB2-Ci

(Three way horizontal centre with
a PMC 75mm mid and
a PMC 10" Piston bass driver)

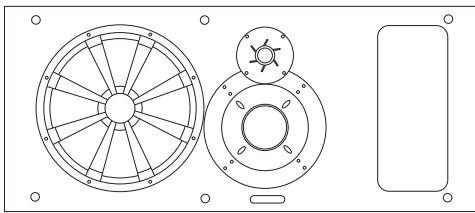

MB2-Ci

(Three way horizontal centre channel
with a PMC 75mm mid and a
12" Radial™ bass driver)

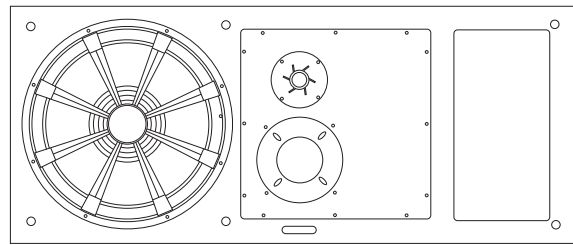

BB5-Ci.

(Three way horizontal centre channel
with a PMC 75mm mid and a
15" Radial™ bass driver)

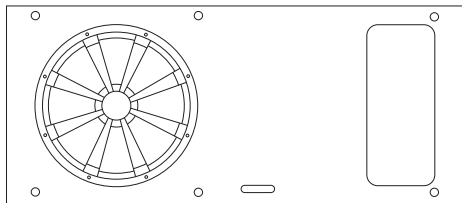

XB2

(Passive subwoofer with a
12" Radial™ bass driver for a MB2i
based surround system)

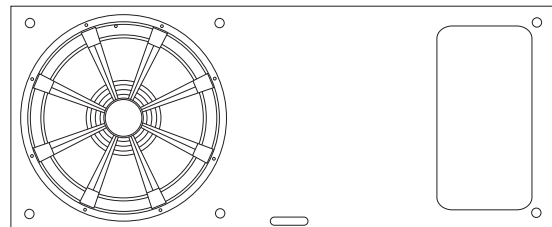

XB3

(Passive subwoofer with a
15" Radial™ bass driver for a BB5i based
surround system)

service

We are confident your **wafer**™ loudspeakers will afford many years of trouble-free listening of the highest order, but in the unlikely event that one or more requires repair, our unique manufacturing procedure, wherein the precise value of each component together with the response of the system as a whole is recorded, will ensure that any replaced parts will exactly match the performance of those originally included within each individual loudspeaker.

For any issues that might arise or for advice and service requirements, the primary point of contact should be your knowledgeable and authorised PMC dealer/distributor. If you do not have a local representative please see www.pmc-speakers.com and click on distribution.

Important Note: Please do not return any products to PMC directly without first contacting our support department and obtaining a Return Authorisation Number.



warranty on-line

**SIMPLY ACTIVATE YOUR 5 YEAR
WARRANTY ON-LINE**

GO TO WWW.PMC-SPEAKERS.COM AND CLICK ON REGISTER PRODUCT



**If you do not have access to the internet fill in the
warranty form found on pages 26 & 27 and post it to us.**

warranty certificate - part 1

your copy
to **KEEP**

Please complete and retain this page for your own records

Product

Serial Nos

Date of purchase

Dealers name

Dealers address

Town

County

Postcode

Dealers Telephone No

Servicing and warranty issues – Please read the following carefully.

Non UK clients

Contact your local dealer/distributor for the details of warranty repairs - see www.pmc-speakers.com and click on distribution for their details.

UK clients

In the unlikely event of a fault occurring with your PMC product firstly contact your dealer where the product was purchased.

Do not return a product to PMC Ltd without firstly contacting our technical dept. If the product must be returned for service you will be issued with a Returns Authorisation number.

If a product is returned to PMC Ltd and subsequently is found to have no fault or a non-warranty fault it will be subject to a minimum of £50.00 plus the carriage for its return.

Proof of purchase is required for any claim covered by this warranty.

This product is warranted for a period of 5 years from the date of purchase or upon receipt of 'our copy' overleaf or on-line registration within ten days of purchase or receipt.

The warranty covers defects due to faulty materials or workmanship but does not cover defects arising from accidental damage, misuse or wear and tear. The warranty is void if any attempt has been made by persons not authorised by PMC Ltd to dismantle, repair or modify any part of the product.

Products must be returned using original packing material. This warranty does not cover damage in transit.

Note that the cost of the carriage to PMC is not covered by the warranty.

Returned products that are defective that are covered by warranty will be repaired or replaced at the discretion of PMC Ltd.

Allow minimum of 14 working days for return of warranty repairs.

This warranty does not effect your consumer rights under statutory law. This warranty certificate is only valid in the United Kingdom.

PMC LIMITED 43-45 Crawley Green Road Luton LU2 0AA UK T +44 (0) 870 4441044 F +44 (0) 870 4441045

warranty certificate - part 2

our copy

Please complete and return this section - or simply complete the on-line registration at www.pmc-speakers.com and click on register product.

Help us improve
our products
see over

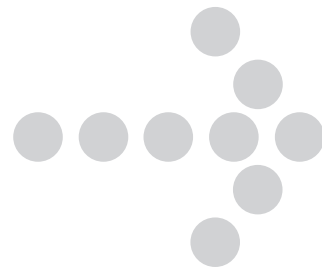

help us improve

your comments

We value all our client's comments. Please take a moment to help us improve:

If there is one thing we should change, what would it be?

Please tell us how your new PMC's perform. Your comments may appear on the customer quotes section for this product on our site. N.B. Don't worry the comments will be anonymous; your personal details will not appear.

What magazines do you read?

HiFi	Pro	Lifes style	Online
<input type="checkbox"/> HiFi Choice	<input type="checkbox"/> Future Music	<input type="checkbox"/> T3	<input type="checkbox"/> mixonline.com
<input type="checkbox"/> What HiFi	<input type="checkbox"/> Sound on Sound	<input type="checkbox"/> Stuff	<input type="checkbox"/> gearslutz.com
<input type="checkbox"/> Stereophile	<input type="checkbox"/> Audio Media	<input type="checkbox"/> GQ	<input type="checkbox"/> avreview.co.uk
<input type="checkbox"/> HiFi World	<input type="checkbox"/> Pro Sound News	<input type="checkbox"/> Boys Toys	<input type="checkbox"/> avforums.com
<input type="checkbox"/> HiFi Critic	<input type="checkbox"/> Resolution	<input type="checkbox"/> FHM	<input type="checkbox"/> HiFi WigWam.com
<input type="checkbox"/> HiFi News	<input type="checkbox"/> Audio Fanzine	<input type="checkbox"/> Shortlist	<input type="checkbox"/> What HiFi.com
<input type="checkbox"/> HiFi+	<input type="checkbox"/> IBE	<input type="checkbox"/> Maxim	<input type="text" value="Other"/>
<input type="checkbox"/> Gramophone	<input type="checkbox"/> Line Up	<input type="checkbox"/> Esquire	
<input type="text" value="Other"/>	<input type="text" value="Other"/>	<input type="text" value="Other"/>	

We hope you enjoy your latest purchase as much as we enjoyed designing and building them - Thank you.

specifications

	wafer 1™	wafer 2™
Freq response	50Hz-25kHz	40Hz-25kHz
Sensitivity	87dB 1w 1m	90dB 1w 1m
Impedance	8 Ohms	8 Ohms
Drive Units	LF 140mm (5½") HF 2 x 27mm Soft dome	LF 170mm (6½") HF 2 x 27mm Soft dome
Input connectors	1 pair 4mm sockets	1 pair 4mm sockets
Dimensions	H x W x D	H x W x D
Cabinet	500 x 235 x 100mm (19.7 x 9.3 x 4 inches)	575 x 355 x 100mm (22.6 x 14 x 4 inches)
Cabinet with grille	516 x 267 x 108mm (20.3 x 10.51 x 4.25 inches)	591 x 387 x 108mm (23.27 x 15.24 x 4.25 inches)
Weight	5kg (11 lbs)	6.6kg (14.5 lbs)
Colours	White, Black	White, Black

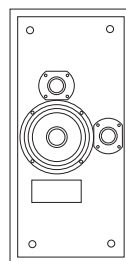

wafer 1™

(Two way on-wall monitor)

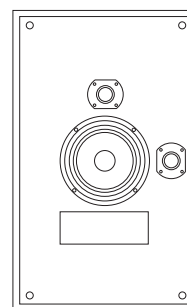

wafer 2™

(Larger, Two way on-wall monitor)

inspection certificate

Every component that appears in a PMC product is measured, tested, matched and recorded by hand. This analysis also applies to the final product with the addition of the ultimate test of the human ear. We simply listen to every product we make to ensure you receive an identical replica of the reference model.

Enclosure finish

Assembly & Wiring

Driver Installation

Enclosure seal test

Level - Frequency test

Impedance - frequency test

Listening test 1

Listening test 2

Final inspection

Accessory pack

User Guide included

all the above checked by

Date



PMC LIMITED

43-45 CRAWLEY GREEN ROAD LUTON LU2 0AA UK

T +44 00 (0)870 4441044 F +44 00 (0)870 4441045

email sales@promonitor.co.uk web www.pmc-speakers.com

PMC USA LLC

17952 SKY PARK CIRCLE Building 45 SUITE A IRVINE CA 92614 USA

T 949 861 3350 F 949 861 3352

email sales@pmc-speakers.us web www.pmc-speakers.com